

LAYOUT

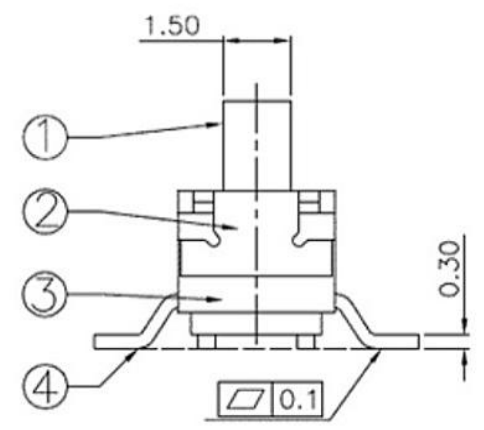
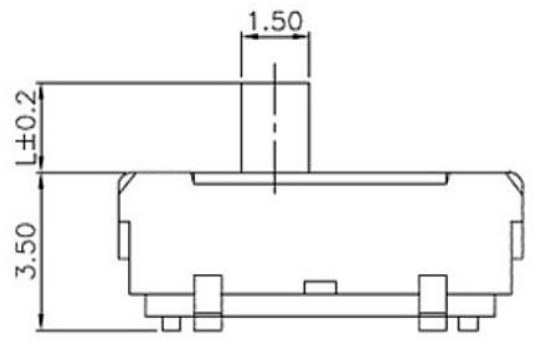
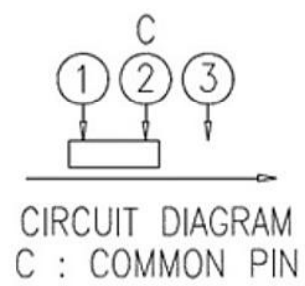

注: "\*"表示关键尺寸(6个)

NO.	PARTS	MATERIALS	Q'TY	FINISH	TOLERANCE		UNLESS SPECIFIED		DESCRIPTIONS OF REVISION		APPD.
8											
7	STEEL BALL	STEEL	1	NATURAL							
6	SPRING	STEEL WIRE	1	NATURAL							
5	CONTACT CLIP	PBS STRIP	2	Ag PLATED							
4	TERMINAL	BRASS STRIP	8	Ag PLATED							
3	BASE	PHENOLIC RESIN	1	NATURAL							
2	FRAME	STEEL STRIP	1	Ni PLATED							
1	KNOB	POM	1	BLACK							
					TITLE : SLIDE SWITCH			UNIT : mm	DRWG NO.:		
					MODEL:			SCALE: 3:1	DWN.		2012-10-26
					东莞市高迪电子有限公司 DONGGUAN GAODI ELECTRONICS CO., LTD.				CHK'D		2012-10-26
									APPD.		